

0  
5 Centimetres  
10  
15  
20  
25  
30

**FIG 1B**  
50/1200 LINE PABX

AS SEEN FROM REAR

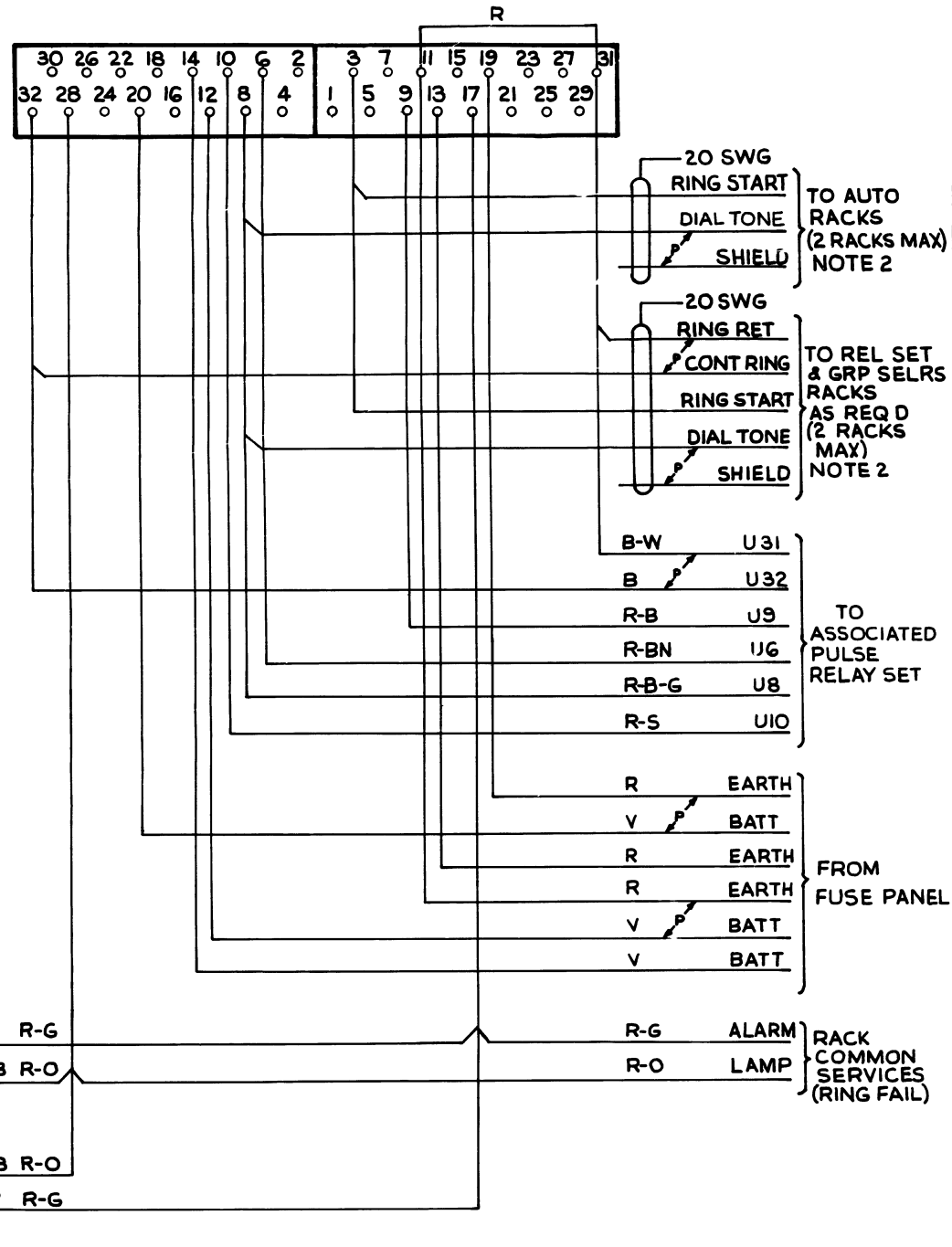

**NZ NOTES**

A WHEN GBW 16761 IS USED AS AN ALTERNATIVE FOR GBW 13250, GBW 14130 OR GBW 14700 USE GBU 13250, GBU 14130 OR GBU 14700

**FIG 1A**

20, 35 OR 49 LINE PABX

AS SEEN FROM REAR

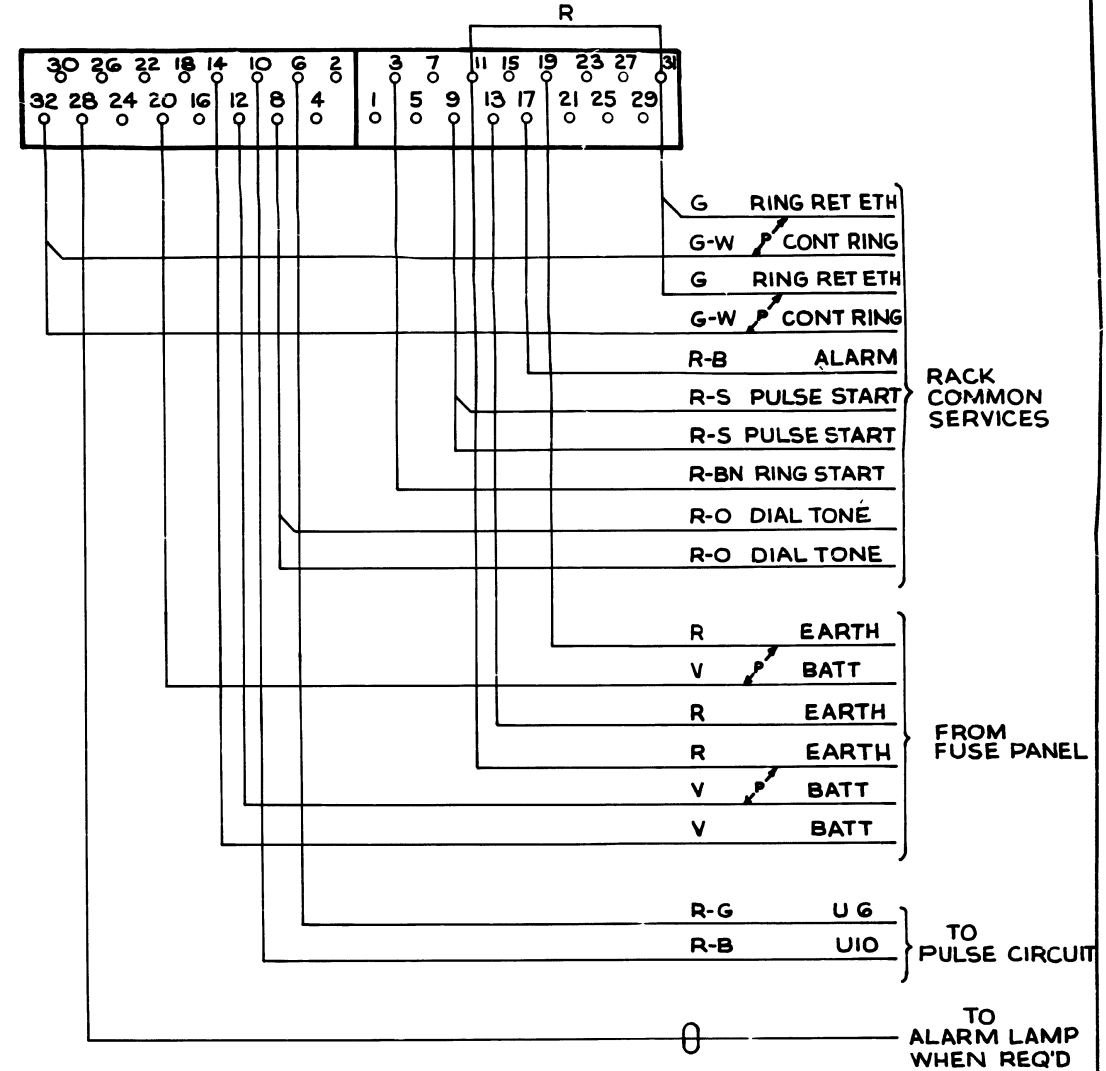

**NOTES**

- FIG 1A ALL WIRING TO BE 25 SWG  
FIG 1B ALL WIRING TO BE 22 SWG
- EACH FIG 1B MUST SERVE THE SAME RACK OR RACKS AS ASSOCIATED PULSE RELAY SET
- ON SOME EARLY EQUIPMENT BATT WIRING IS BK

				PABX	
				RINGING & TONES CIRCUIT	
RETRACED	(86534)	3A	19 8 75	GFE	
NZ NOTE A ADD	(8429)	3A	22 4 71	GFE	
16761 ADD TO DGM N°	NOTE 3 ADD (16010)	3	16 7 70	GJD	
AMENDMENT PARTICULARS			ISSUE DATE	APP <sup>o</sup>	SIZE S   50 V   E
NZ PO		DRAWN	CHECKED	WIRING	CIRCUIT
				GBU 16760 GBU 16761	