

AS SEEN FROM REAR

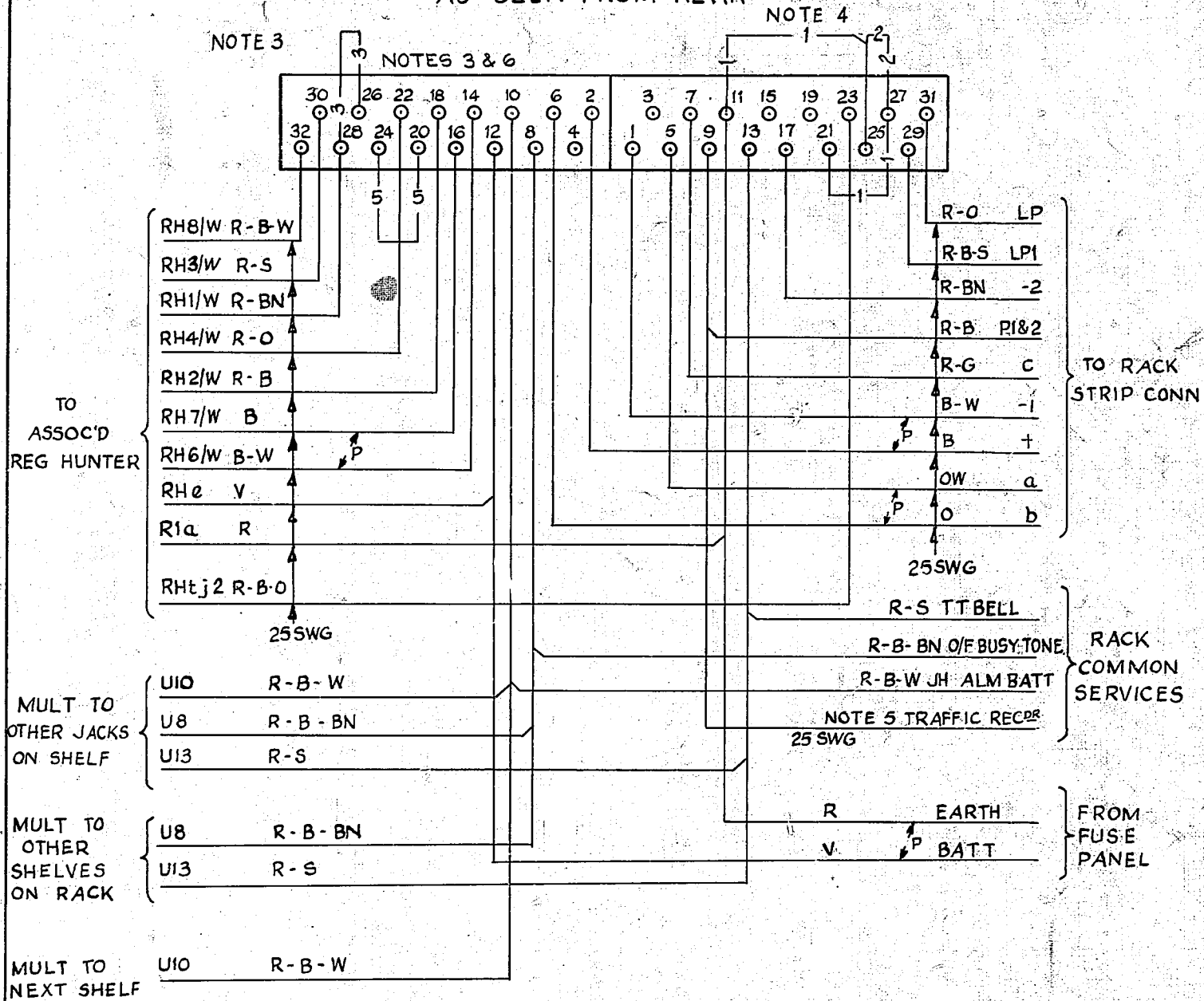

NOTES

- ALL WIRING TO BE 22SWG UNLESS OTHERWISE SPECIFIED.
- SHELF JACK U-POINTS 9 & 11 MAKE CONTACT WHEN RELAY SET IS MOVED
- WHEN REGISTER PRESELECTION FEATURE IS NOT REQUIRED DELETE STRAP BETWEEN U26-28 SHOWN THUS — 3 — 3 —
- WHEN CONNECTED TO A 2-WIRE ROTARY GRP. SELR. ADD STRAP U25-27 SHOWN — 2 — 2 —
" " " " 3 " " " " STRAPS U25-11 & U27-21 SHOWN — 1 — 1 —
- COLOURS FOR TRAFFIC RECORDER LEAD-SHELVES A&B R-O; SHELVES C&D R-G
" E&F R-BN
- STRAP U 20-U24 AS SHOWN — 5 — 5 — WHEN RELAYSET IS ASSOCIATED ONLY WITH THE TOLL SWITCHING TRAIN AND MANUAL HOLD FACILITY IS REQUIRED.
- ON SOME EARLY EQUIPMENT BATTERY WIRING IS BK.

				INTERWORKING RELAY SET (TYPE SR3)	
				STEP BY STEP TO ROTARY 3- SELECTION	
O/F BUSY TONE WAS N.U. TONE. NOTE 7 ADDED (86256)				3	18-8-69
NOTE 6 AND ASSOCIATED CONNECTION ADDED (72821)				2	2-6-67
(72205)				1	5-2-64
AMENDMENT PARTICULARS				ISSUE	DATE
				APPD	50V E
N.Z.P.O.		DRAWN	CHECKED	WIRING CIRCUIT	GBU 11171